

HPAC April 2009

By: John Siegenthaler, P.E.

© Copyright 2009, J. Siegenthaler, all rights reserved
used with permission

Integrating Wood & Water (part 1)

How to set up a wood-fired boiler for hydronic heating

In rural upstate New York where I live, many homes, and even some commercial buildings are heated by wood-burning devices. Although the majority of these devices are simple wood stoves, those who make a major commitment to wood-fired heating, especially in new construction projects, often opt for hydronic-based delivery of wood-generated heat.

Some are interested in using a wood-fired boiler as their sole heat source. Others want the wood-fired boiler to serve as the primary source, but have an oil-fired or gas-fired boiler turn on automatically as a backup. Both are possible, and both can exploit the flexibility of hydronics to rein-in the operating characteristics of a wood-fueled heat sources.

Burn It Hot: One simple fact of wood burning is that high combustion temperature equals high efficiency. When wood is sufficiently heated it gives off pyrolytic gases. Given high enough temperatures and the presence of oxygen, these gases combust to liberate heat. However, if the temperature in the combustion chamber is too low, or the combustion zone is starved for oxygen, a significant portion of the pyrolytic gases will not combust. Instead they will pass into the chimney, cool, and condense as creosote - a sticky, tar-like substance that eventually hardens in layers against the chimney walls.

Creosote left unattended is a disaster waiting to happen. Because it's formed from unburned hydrocarbons, creosote has considerable fuel value. If reheated to a sufficient temperature by other combustion products, or directly by flames, that fuel value can quickly reappear in the form of a chimney fire. Although I've never witnessed one personally, I've heard chimney fires can make a sound comparable to that of a roaring jet engine. Not exactly what you want to wake up to on a cold winter night. Every winter, the local news carries stories of houses lost to chimney fires.

One of the best ways to minimize creosote formation, and boost efficiency is to burn firewood as fast and hot as possible. Many wood-fired boilers are now designed to do this using a combustion air blower and ceramic combustion chamber. These wood-gasification boilers can create combustion zone temperatures over 2000 °F, and corresponding efficiencies over 80%. This form of combustion leaves very little residue. Much less than is typical with a wood stove.

Intermittent Heat: Perhaps the most challenging issue associated with wood-burning boilers is that the fire cannot be instantly turned on and off as is can with an oil- or gas-fired boiler. There will be times when the heat output of the boiler exceeds the heating load of the building. There will also be times when the output from the wood-fired boiler cannot satisfy the load.

The degree to which the boiler can regulate its heat output plays a major role in how that boiler is piped and controlled in the system. This is also determined, in part, by how the owner chooses to operate the wood-fired boiler.

For example, suppose the owner isn't available to tend the boiler every two or three hours. Instead, they stuff the fire box full of wood in the morning, light the fire, and let the boiler operate at full capacity until it

completely burns off that fuel load. Perhaps they set up a similar cycle in the evening.

Consider how the boiler responds to this operation based on its controls. Most wood-fired boilers have an upper temperature limit control like on oil- or gas-fired boiler. When the boiler reaches its high temperature limit setting the combustion air blower (if present) is turned off, and the air damper usually moves to a minimum setting so as not to completely starve the fire for air.

If the boiler has significant thermal mass, (e.g. a high water volume), it should be able to standby at minimum fire until the load again calls for heat. At that point the combustion process is automatically stoked, and the cycle repeats itself. Boilers that fit this description can be piped into a system as shown in figure 1.

[figure 1]

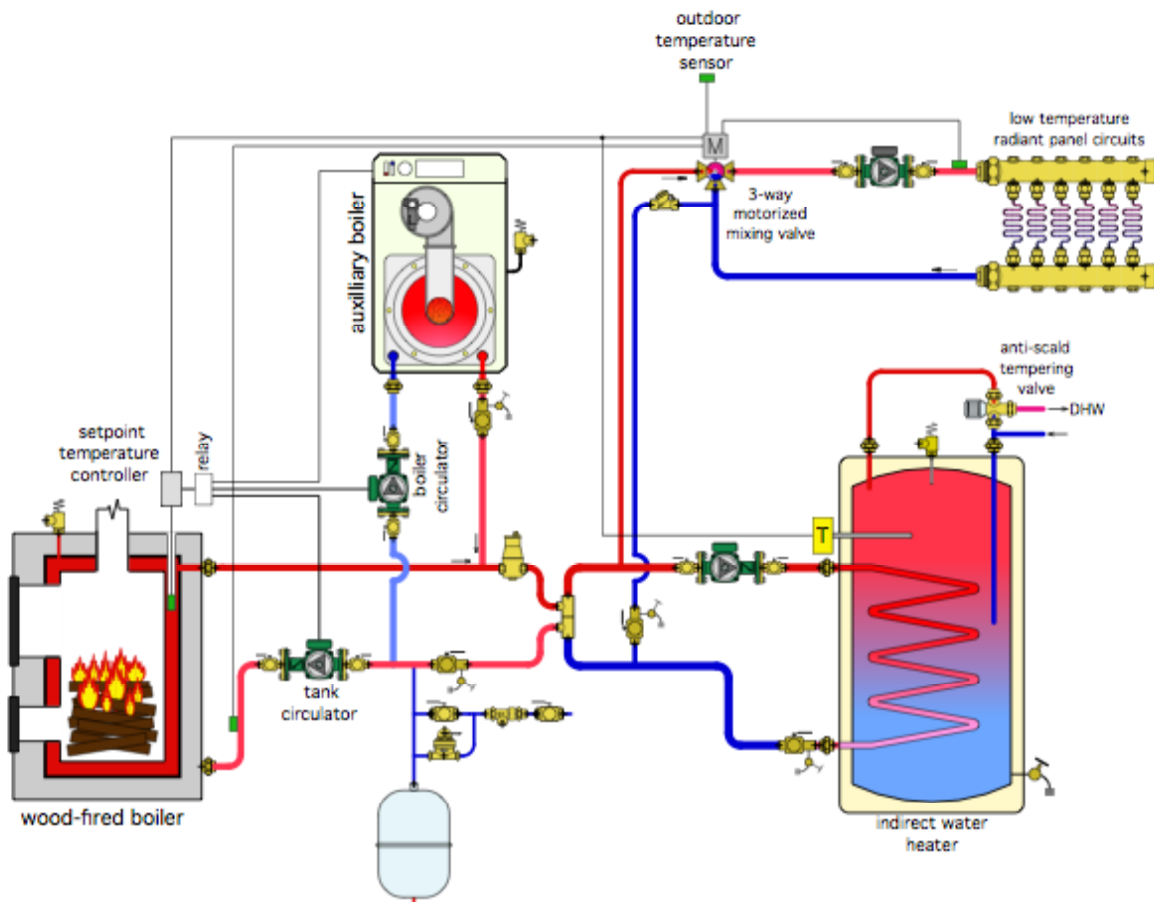

Here the wood-fired boiler is assumed to be a pressure vessel just like the conventional boiler. A simple setpoint controller monitors the temperature of the water in the wood-fired boiler. When there is a demand for heat from either the space heating system or the domestic water heater this controller makes the decision about which boiler supplies the heat. If the wood-fired boiler is hot enough it gets the nod. If not, the auxiliary boiler is called into service.

The sensor monitoring the inlet temperature of the wood-fired boiler allows the 3-way motorized mixing valve to modulate as necessary to protect that boiler for low temperature operation and the subsequent formation of creosote.

Although this control configuration is acceptable, it is not as versatile as other methods to be described later in the article.

BTU Parking: When the boiler does not contain a substantial amount of water its output can be difficult to control, especially if the load is highly variable, and/or the owner chooses to fire the boiler with one “batch” of wood at a time. This is where a buffer tank capable of storing excess heat output from the boiler can really help.

Buffer tanks can be either pressurized or unpressurized. An unpressurized tank is essentially an insulated cistern with a cover. The water it contains is not isolated from the atmosphere, and thus the tank will not allow a positive pressure to develop. An example of a system using an unpressurized buffer tank is shown in figure 2.

[figure 2]

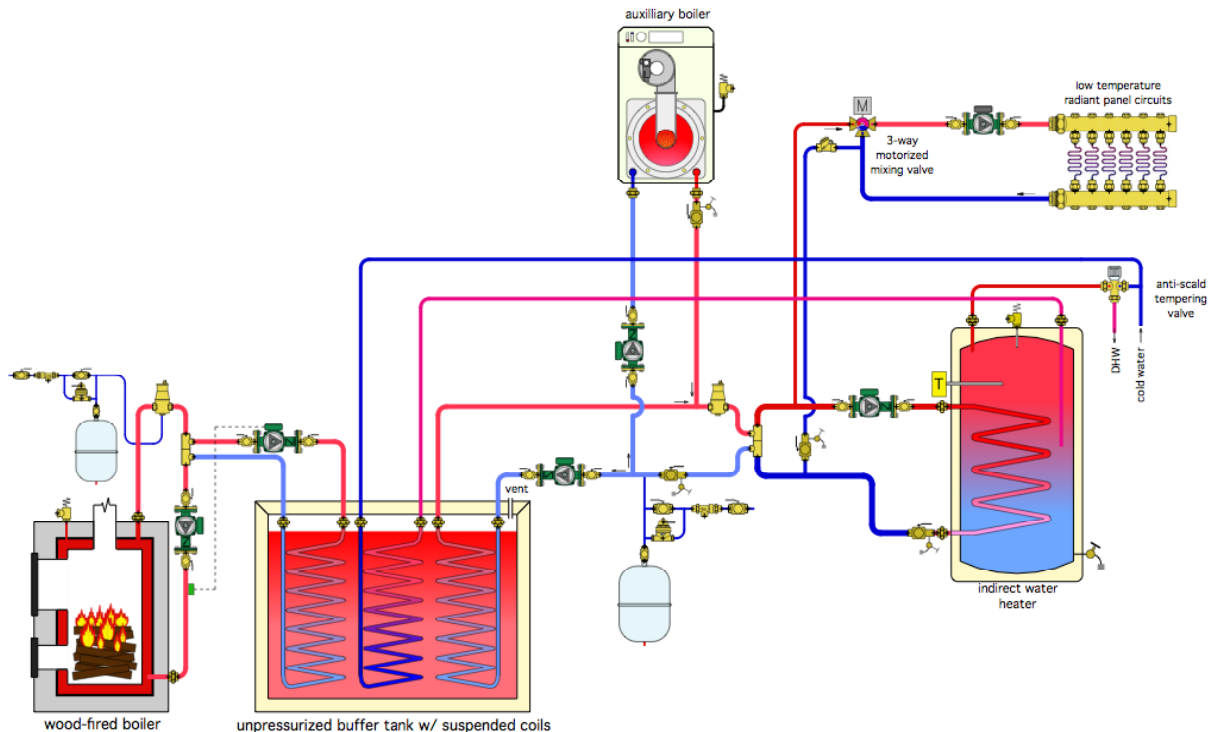

The unpressurized buffer tanks used with wood-fired boilers typically have at least two copper coil heat exchangers suspended within the tank. Each coil is part of a separate closed and pressurized hydronic circuit: One that delivers heat from the boiler to the tank, and the other that extracts heat from the tank for the distribution system. This approach allows the use of site-built unpressurized tanks, yet retains the advantages of closed / pressurized hydronic circuits. The fact that the tank water is isolated from either circuit also means the expansion tank(s) in the closed circuits don't have to be sized to handle the expansion of perhaps several hundred gallons of water in the buffer tank.

A third coil is often added to the tank for domestic water heating. Even a fourth coil could be added to input heat from a solar thermal subsystem. We'll look at solar input in part 2 of the article.

The downside to an open tank is that evaporation losses occur over time, and it is necessary for someone to periodically check tank water level and add make-up to keep all coils fully submerged.

Control Sequence: The controls used for systems with wood-fired boiler can vary considerably depending on how the system is intended to operate, the presence or lack of a buffer tank, and the loads being served.

We will look at several control options. They all assume a piping design in which all heat from the wood-fired boiler is dumped into a buffer tank. The buffer tank then serves as the prior source of heat for both space heating and domestic water heating. The auxiliary boiler is only turned on when the wood-fired boiler can no longer supply heat to either of these loads.

The first control sequence we'll discuss also assumes that the heat extraction coil in the buffer tank could serve as the heat source to the coil heat exchanger in the indirect water heater. The piping diagram of figure 2 has been further embellished with control hardware in figure 3.

[figure 3]

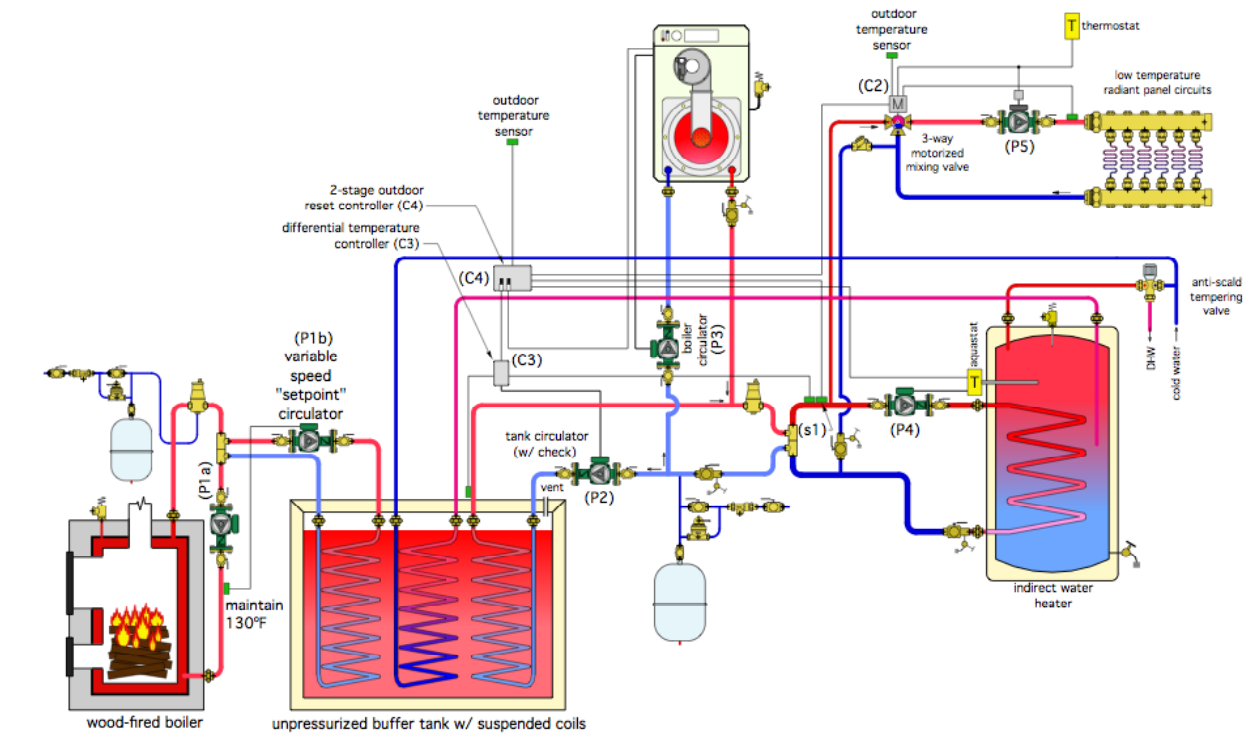

Here's how the system would operate:

1. The fan and damper on the wood-fired boiler operate based on boiler limit controller. Whenever there is a call for heat, or boiler water is above a set temperature, boiler circulator (P1a) operates. Circulator

(P1b) is variable speed setpoint controlled circulator. Its function is to prevent the wood-fired boiler from operating at water temperatures low enough to cause creosote formation. It monitors boiler inlet temperature and runs at a speed that allows the boiler inlet temperature to stay above a minimum setting (say 140°F).

2. Upon a call for space heating, the controller (C2) operating the mixing valve calculates the necessary water supply temperature to the radiant panel circuits. It also calls for heat by closing a set of contacts. This provides a space heat demand to a two-stage outdoor reset controller (C4). If there is a call for domestic water heating from the tank aquastat, the 2-stage outdoor reset controller (C4) receives a demand for DHW heating. This portion of the control sequence is essentially identical to how a conventional heating system with the same loads would be controlled.

3. At this point there will be flow past the supply temperature sensor (S1) at the outlet of the closely spaced tees (either circulator P4 or P5 will be operating). If the temperature at sensor (S1) is below the calculated target temperature for the load calling for heat, the first stage contacts of the 2-stage outdoor reset controller (C4) close. This provides low voltage power to the differential temperature controller (C3), which compares the temperature at the outlet of the heat extraction coil to the temperature at outlet of closely spaced tees leading to the distribution system. If the heat extraction coil is at least 5 °F above the supply temperature to the distribution system, the controller (C3) turns on the tank circulator (P2) to supply the load. The auxiliary boiler and its circulator remain off.

4. If the temperature differential measured by (C3) drops to 2°F or less, controller (C3) turns off the storage tank circulator. At the same time the PID logic in controller (C4) monitors the temperature at sensor (S1). If this temperature is insufficient for the load, controller (C4) closes its stage 2 contacts, which fires the boiler and turns on the boiler circulator (P3). The temperature at sensor (S1) begins to climb and the differential temperature controller quickly responds by turning off the tank circulator (P2). This is essential so heat from the auxiliary boiler does not end up being sent into the buffer tank.

5. If the temperature in the buffer tank goes back up, (perhaps the owner has stoked up the fire), the differential temperature controller (C3) will eventually turn the tank circulator back on to send heat to the load. As the temperature at sensor (S1) climbs the second stage contact of controller (C4) will eventually open to turn off the auxiliary boiler.

The 2-stage outdoor reset controller (C4) distinguishes between a call for space heating and for domestic water heating. The latter is always treated as a priority load. When there is a call for space heating, and the auxiliary boiler is fired, its temperature is regulated by its own reset logic. When there is a call for domestic water heating the auxiliary boiler targets a higher temperature to quickly recover the temperature in the indirect water heater.

In this application the 2-stage boiler controller (C4) must NOT be set to allow boiler stage rotation.

This control concept has the advantage of making the decision on using heat from the buffer tank versus the auxiliary boiler based on the actual water temperature supplied to the load. This can be different from the water temperature in the storage tank for a couple of reasons:

a. The water temperature leaving the heat extraction coil will typically be less than the water temperature in the buffer tank. This difference is necessary for heat to transfer from the buffer tank water to the water within the heat extraction coil. How much lower depends on the effectiveness of the coil heat exchanger. If the heat exchanger has a small surface area relative to the load the temperature leaving the coil could be substantial, perhaps 5 to 10 °F less than the tank temperature.

b. There may be mixing at the closely spaced tees that separate the space heating load circuits from the boiler and buffer tank portion of the system. This occurs whenever the flow rate in the distribution system is greater than that from the heat supply portion of the system.

In part 2 we will look at different piping and control options.

Integrating Wood & Water (part 2)

In part 1 of this article we looked at a piping diagram for integrating a wood-fired boiler along with an auxiliary boiler for supply both space heating and domestic water heating. We also took a detailed look at one control sequence and the required control hardware to operate this system.

Now we are going to look at some alternative piping and control options.

The system in figure 4 shows a pressurized buffer tank as an alternative to the unpressurized tank shown in part one of this article. The water in this tank can flow directly to the space heating load. The tank has a single suspended coil heat exchanger for domestic water heating. As with any buffer tank, high levels of insulation (R-15 °f•hr•ft²/Btu minimum) are essential in keeping control over those storage Btus.

[figure 4]

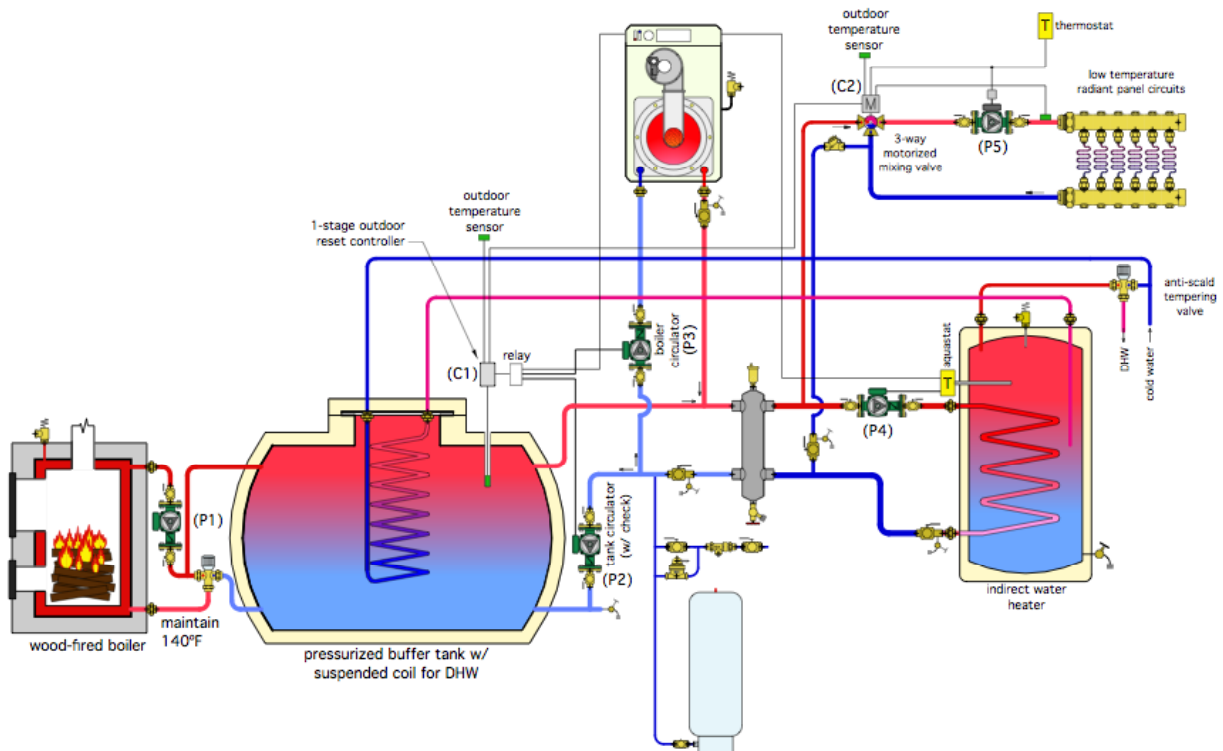

The size of this system's expansion tank is substantially larger than the one used in the system with the unpressurized buffer tank. That's because the expansion tank now must absorb the expansion volume of the water in the buffer tank as well as that in the system's piping. The buffer tank might contain several

hundred gallons of water, and vary from room temperature to perhaps 200 °F. That combination makes for a substantial expansion volume, and thus a floor mounted expansion tank will likely be required.

Another change is the hardware used to prevent low temperature water from creating creosote within the boiler. A 3-way thermostatic valve with sufficient flow capacity (high Cv) continually measures the water temperature entering the boiler. If this temperature is below a minimum preset value, the thermostatic valve routes some of the water leaving the boiler back into the boiler. At the same time it reduces flow from the boiler to the buffer tank. The valve serves as a “thermal clutch” to ensure that a cool buffer tank cannot hold the boiler in a flue gas condensing mode. It’s the same type of protection required with a conventional gas- or oil-fired boiler.

One other alternative is the hydraulic separator replacing the air separator and closely spaced tees at the interface to the distribution system.

None of these alternatives are necessarily better than those described in part 1. They are shown simply to point out flexibility in the hardware configuration.

How It Operates: When it comes to control for this system we’re going to simplify the requirements a bit relative to those used in part 1. Here is the change: Assume the only way the wood-fired boiler heats domestic water is as that water passes through the suspended coil in the buffer tank. In other words, the buffer tank can not serve as a heat source for the coil of the indirect water heater as it did in part 1.

The auxiliary boiler can still boost domestic water temperature within the indirect tank when necessary. It can also supply the space heating load when the buffer tank cannot.

With this assumption in mind, here is a description of the control operation for the system shown in figure 4.

1. The fan and damper on the wood-fired boiler operate based on boiler limit controller. Whenever there is a call for heat, or boiler water is above a set temperature, boiler circulator (P1) operates. If the water temperature exiting the 3-way thermostatic is too low, most of the water coming from the boiler will be shunted back to the boiler to avoid creosote formation. As the boiler temperature rises this valve diverts water from the boiler into the buffer tank. This action prevents the boiler from sustained operation at low water temperatures where the formation of creosote is likely.

2. Upon a call for space heating, the mixing valve controller (C2) calculates the necessary water supply temperature to the radiant panel circuits. Controller (C2) calls for heating by closing a set of contacts to power outdoor reset controller (C1), which monitors temperature at top of buffer tank. If this temperature is at or above the calculated target temperature minus half the control differential, the normally closed contacts in the relay adjacent to controller (C1) turn on the tank circulator (P2) allowing the tank to supply heat to the space heating load. If the tank is below this target temperature minus half the control differential the normally open contacts in the relay close to turn on the boiler and boiler circulator (P3). In this case, boiler temperature is regulated by the boiler's internal reset controller. A graph depicting the reset control function provided by controller (C1) is shown in figure 5.

[figure 5]

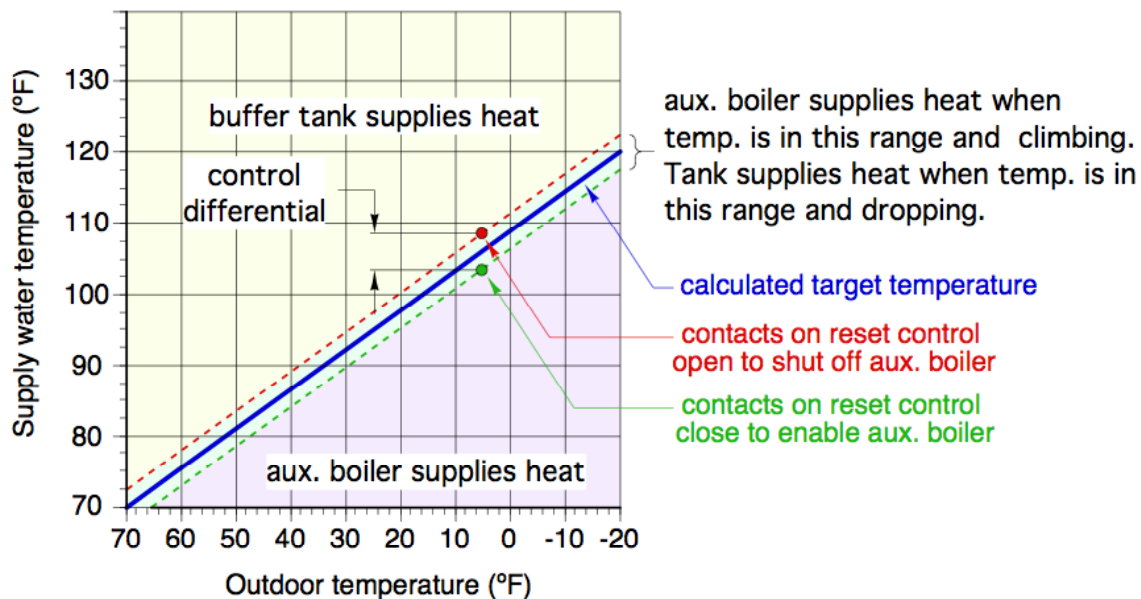

3. Domestic water heating is treated as a priority load. When the aquastat on the indirect water heater calls for heat, the tank circulator (P2), if it's currently running, is turned off. Circulator (P4) is turned on as is the boiler and boiler circulator (P3). Boiler temperature is controlled based on its setting for DHW mode.

Keep in mind that all domestic water that enters the indirect water heater first passes through the suspended coil in the buffer tank. If the water in the buffer tank is relatively warm, say 120 °F, and the suspended coil is generously sized, the vast majority of domestic water heating will take place as the water passes through the coil. The only limitation of this method is that wood-sourced energy cannot "top off" the water temperature in the indirect tank, assuming the temperature of the buffer tank was indeed high enough to do so. I don't see this as a substantial negative considering the simplified controls.

When the Sun Is Out: Given the nice big storage tank in these systems, it's only natural that some owners will want to expand their system to include solar energy input. Free heat from the sun is certainly preferable to burning wood during warmer weather. If a couple of cloudy days are in the forecast just light up the wood-fired boiler, or simply relax and let the auxiliary boiler handle the situation automatically.

This is easy to accomplish. Just add a brazed plate heat exchanger as the interface between a closed-loop antifreeze type solar subsystem and the storage tank as shown in figure 6. Be sure to pipe it for counter-flow (streams flow in opposite directions through the heat exchanger) as shown in the schematic. Also be sure check valves are installed as shown.

[figure 6]

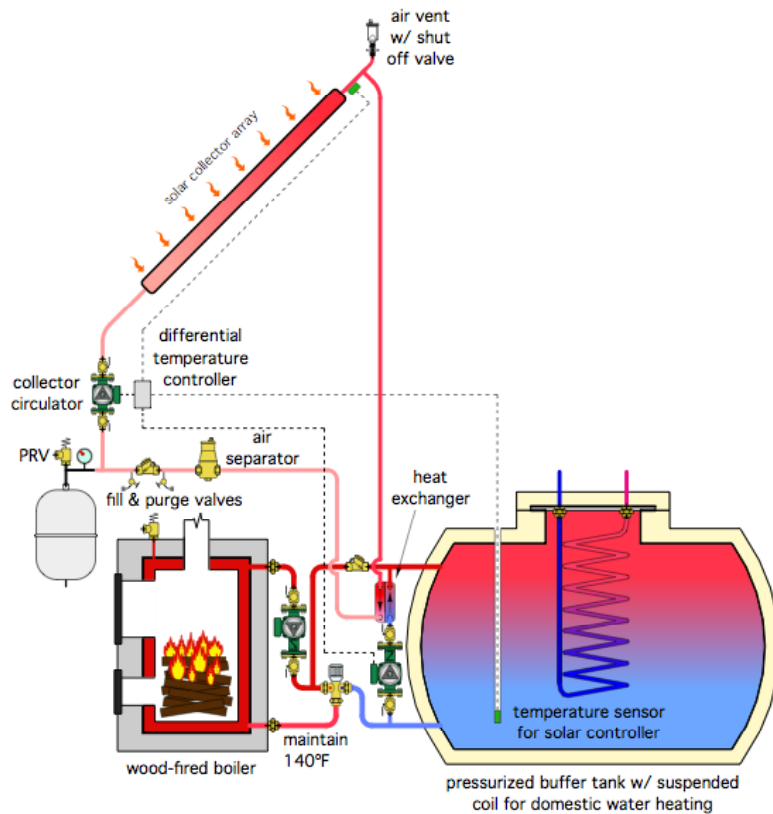

A standard differential temperature controller operates the collector circulator whenever the collector temperature is a few degrees above the temperature at the bottom of the storage tank.

Because the solar collection subsystem is isolated from the remainder of the system it requires its own expansion tank, air separator, pressure relief valve, check valve, and purging valves.

As you can see, there are several ways to interface a wood-fired boiler with a modern hydronic heating system. A well-insulated buffer tank is the key to merging the intermittent operating schedule of most wood-fired boiler with the demands for space and water heating. When done properly, occupants feel no difference in the comfort delivered by the system.

J.S.